

# Enterprise 240

Lay-on metal panel with service zone panels.

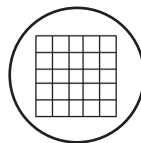

**ENTERPRISE  
ARCHITECTURAL**  
Metal Ceiling Solutions



EXPOSED GRID



UP TO 1.0 NRC



NCC GROUP 1



RECYCLABLE



25 YEAR WARRANTY



<b>Product</b>	Enterprise 240
<b>Grid</b>	Service zone panels available in various sizes. Available in 1-way or 2-way layout options.
<b>Size</b>	Length up to 3000mm, width up to 600mm. Bespoke sizes on request
<b>Material</b>	Steel or Aluminium
<b>Perforation</b>	Compatible with Enterprise perforation patterns, bespoke patterns on request
<b>Finish</b>	Polyester powder-coated (PPC) Timber effect Bespoke finishes on request
<b>Acoustic</b>	Acoustic fleece, pad or board. Performance is dependent on pattern open area and infill. Absorption: up to 1.0 NRC Attenuation: up to 37dB
<b>Fire</b>	NCC Group 1 (ISO 9705:2016)
<b>Environment</b>	Global GreenTag GreenRate Level A Climate Active certified Carbon Neutral opt-in available Low VOC ISO 14001 and ISO 9001 Recyclable and designed for disassembly Product stewardship program
<b>Technical</b>	Services integration supported Seismic: project specific



**Isometric**

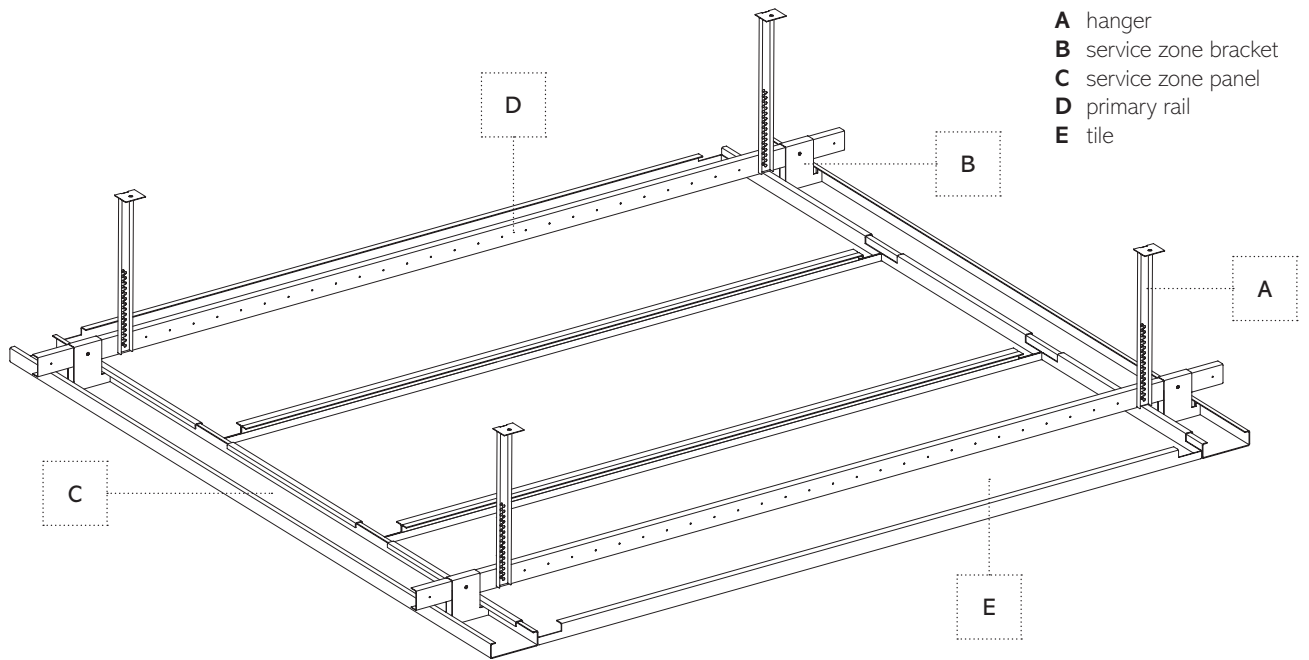

**Section**

