

# Enterprise 200

---

Lay-in metal panel in exposed modular top hat grid.



**ENTERPRISE  
ARCHITECTURAL**  
Metal Ceiling Solutions

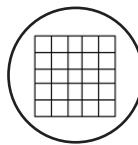

EXPOSED GRID



UP TO 1.0 NRC



GROUP 1



RECYCLABLE



25 YEAR WARRANTY



trust brands

<b>Product</b>	Enterprise 200
<b>Grid</b>	32mm x 50mm aluminium top hat grid, exposed modular 2-way
<b>Size</b>	1200mm x 1200mm, 1350mm x 1350mm, 1500mm x 1500mm. Bespoke modules on request
<b>Material</b>	Steel or Aluminium
<b>Perforation</b>	Compatible with Enterprise perforation patterns, bespoke patterns on request
<b>Mesh</b>	Compatible with Enterprise mesh, bespoke mesh on request
<b>Finish</b>	Polyester powder-coated (PPC) Timber effect Bespoke finishes on request
<b>Acoustic</b>	Acoustic fleece, pad or board. Performance is dependent on pattern open area and infill. Absorption: up to 1.0 NRC Attenuation: up to 37dB
<b>Fire</b>	NCC Group 1 (ISO 9705:2016)
<b>Environment</b>	Global GreenTag GreenRate Level A Low VOC ISO 14001 and ISO 9001 Recyclable and designed for disassembly Product stewardship program
<b>Technical</b>	Services integration supported Seismic: project specific

**Isometric**

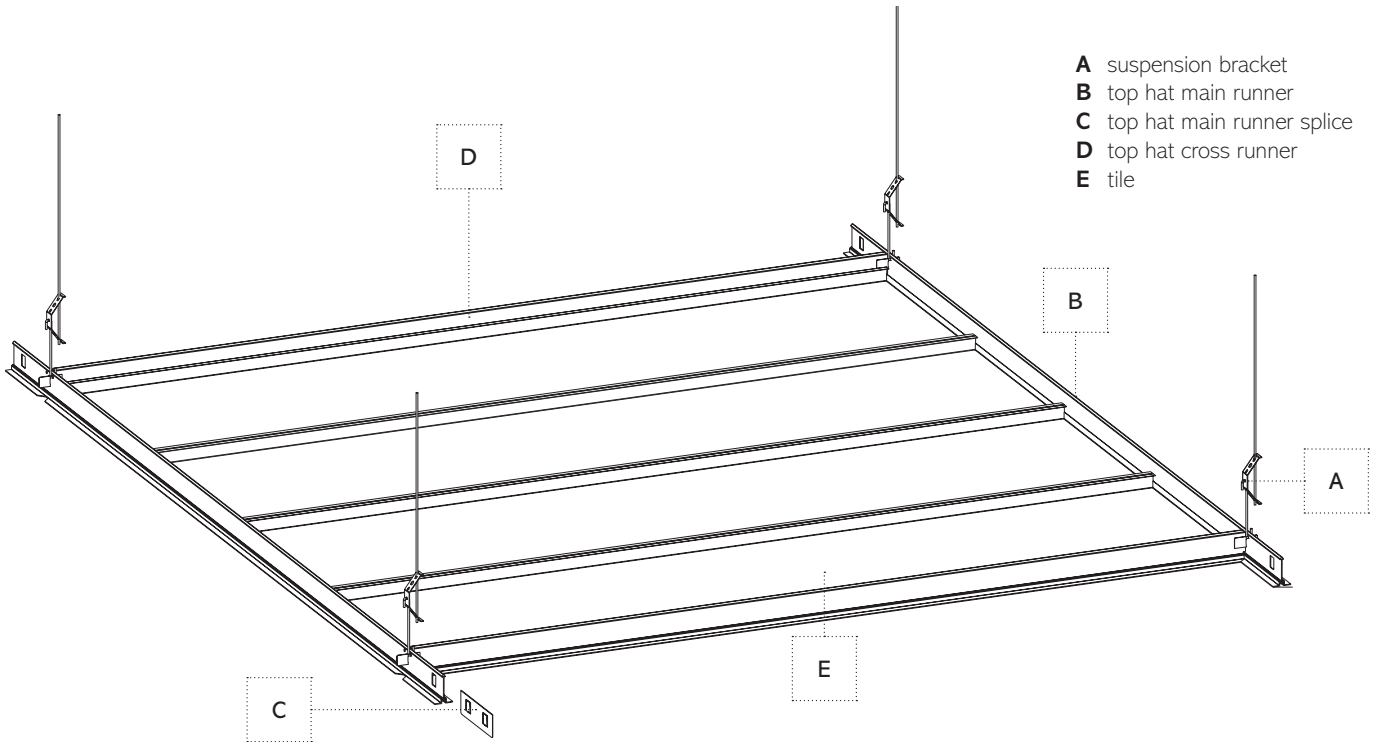

**Section**

