

Enterprise 220

Lay-in metal panel in exposed T bar grid.

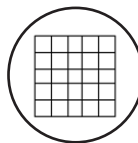

**ENTERPRISE
ARCHITECTURAL**
Metal Ceiling Solutions



EXPOSED GRID



UP TO 1.0 NRC



GROUP 1



RECYCLABLE



25 YEAR WARRANTY



Product	Enterprise 220
Grid	24mm x 38mm aluminium T bar grid, exposed 2-way
Size	1500mm x 500mm, 500mm x 500mm, 1350mm x 450mm, 450mm x 450mm, 1200mm x 600mm, 600mm x 600mm. Bespoke modules on request
Material	Steel or Aluminium
Perforation	Compatible with Enterprise perforation patterns, bespoke patterns on request
Mesh	Compatible with Enterprise mesh, bespoke mesh on request
Finish	Polyester powder-coated (PPC) Timber effect Bespoke finishes on request
Acoustic	Acoustic fleece, pad or board. Performance is dependent on pattern open area and infill. Absorption: up to 1.0 NRC Attenuation: up to 37dB
Fire	NCC Group 1 (ISO 9705:2016)
Environment	Global GreenTag GreenRate Level A Low VOC ISO 14001 and ISO 9001 Recyclable and designed for disassembly Product stewardship program
Technical	Services integration supported Seismic: project specific

Isometric

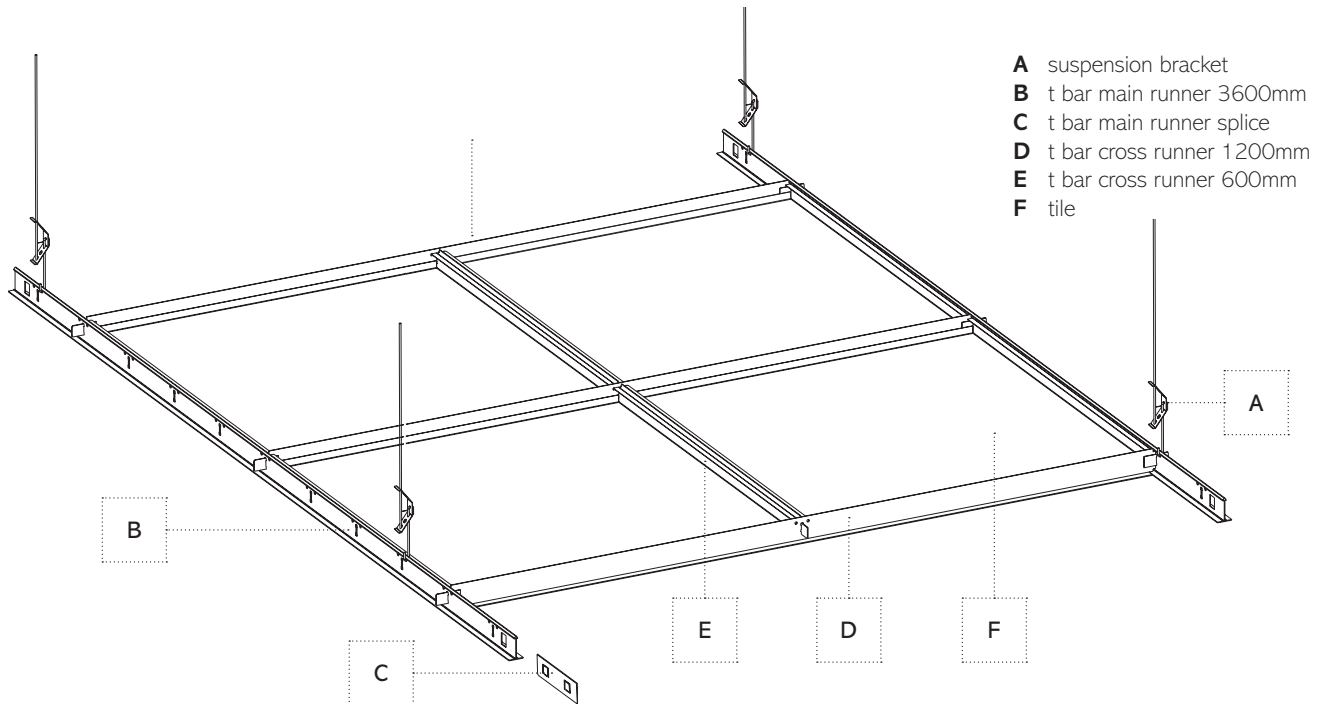

Section

