

# Enterprise 500

---

Open cell lay-in ceiling tiles.



**ENTERPRISE  
ARCHITECTURAL**  
Metal Ceiling Solutions

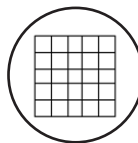

EXPOSED GRID



UP TO 1.0 NRC



GROUP 1



RECYCLABLE



25 YEAR WARRANTY



<b>Product</b>	Enterprise 500
<b>Grid</b>	15mm wide standard T bar grid
<b>Module</b>	1200mm x 600mm and 600mm x 600mm. Bespoke modules on request
<b>Material</b>	Aluminium
<b>Cell Sizes</b>	100mm x 100mm, 150mm x 150mm, 200mm x 200mm. More sizes available on request
<b>Finish</b>	Polyester powder-coated (PPC) Bespoke finishes on request
<b>Fire</b>	NCC Group 1 (ISO 9705:2016)
<b>Environment</b>	Global GreenTag GreenRate Level A Low VOC ISO 14001 and ISO 9001 Recyclable and designed for disassembly Product stewardship program
<b>Technical</b>	Services integration supported Seismic: project specific Note: Tiles are supplied as flat packed to site for easy and safe transport. Tiles are to be assembled on site by the installer.

**Isometric**

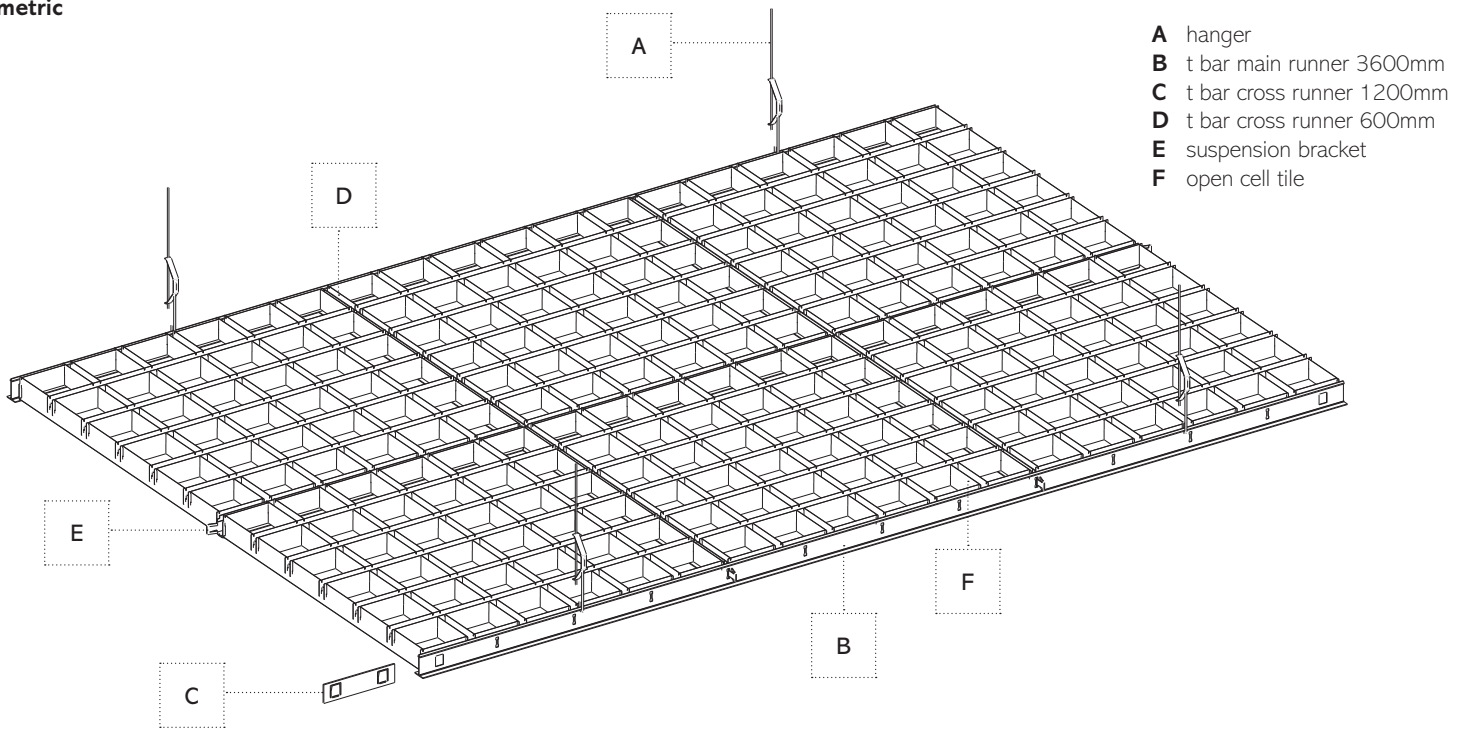

**Section**

