

## TOP HAT 100 SERIES

### Features

Modular configuration allows flexibility in services layout  
 Various module sizes: 1200mm x 1200mm, 1350mm x 1350mm, 1500mm x 1500mm  
 Modules accommodate tile layouts of 3, 4 or 5  
 Metal C Splines 25mm or 35mm to suit tile span  
 Designed with ease of services integration  
 Perimeter trim and pelmet integration  
 Full demountable grid system

### Technical

Dimensions: 32mm (W) x 50mm (H) for both main runner and cross runner  
 Material: 6063 T5 aluminium alloy extrusion  
 Finish: Polyester powder-coated (PPC)  
 Warranty: 25 year

### Isometric

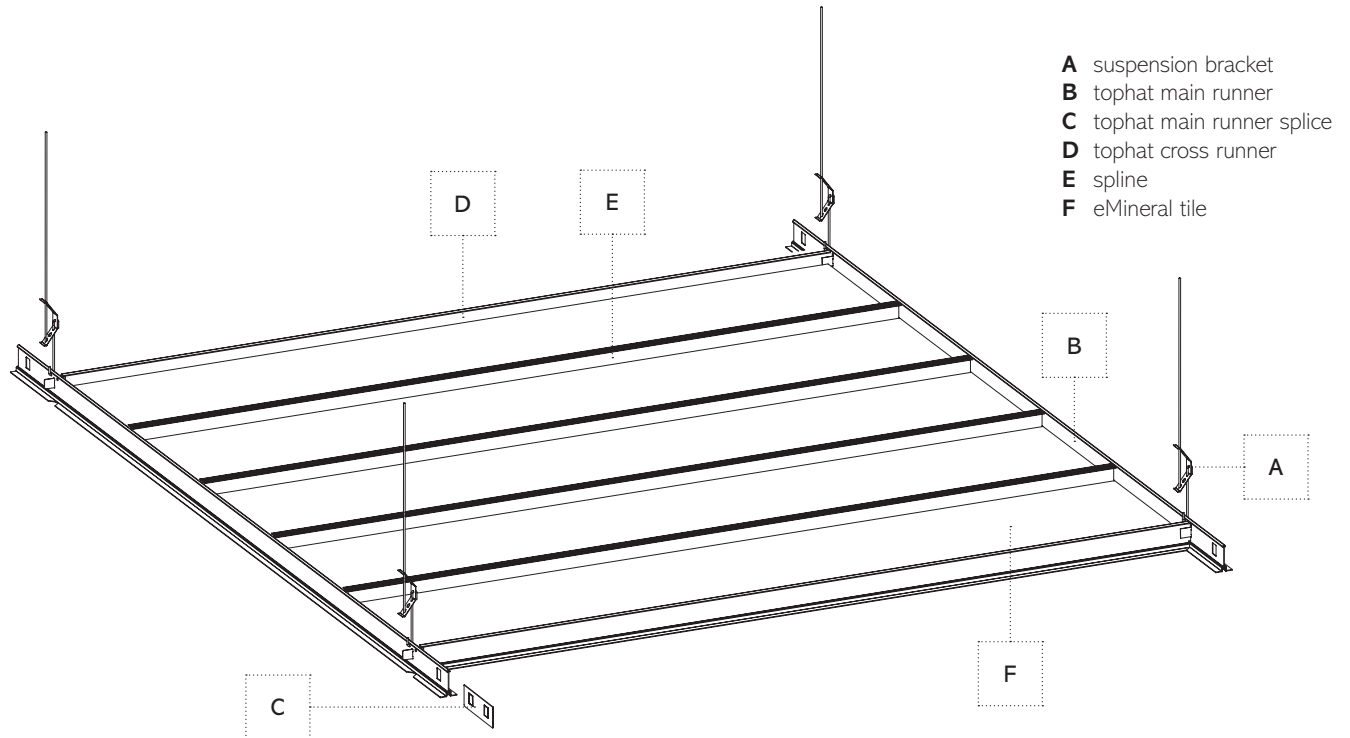

### Section

