

TOP HAT 130 SERIES

Features

One-way exposed top hat grid
Various module sizes available. Maximum module length 1800mm.
Metal C Splines 25mm or 35mm to suit tile span
Designed with ease of services integration
Full demountable grid system

Technical

Dimensions: 32mm (W) x 50mm (H) main runner
Material: 6063 T5 aluminium alloy extrusion
Finish: Polyester powder-coated (PPC)
Warranty: 15 year

Isometric

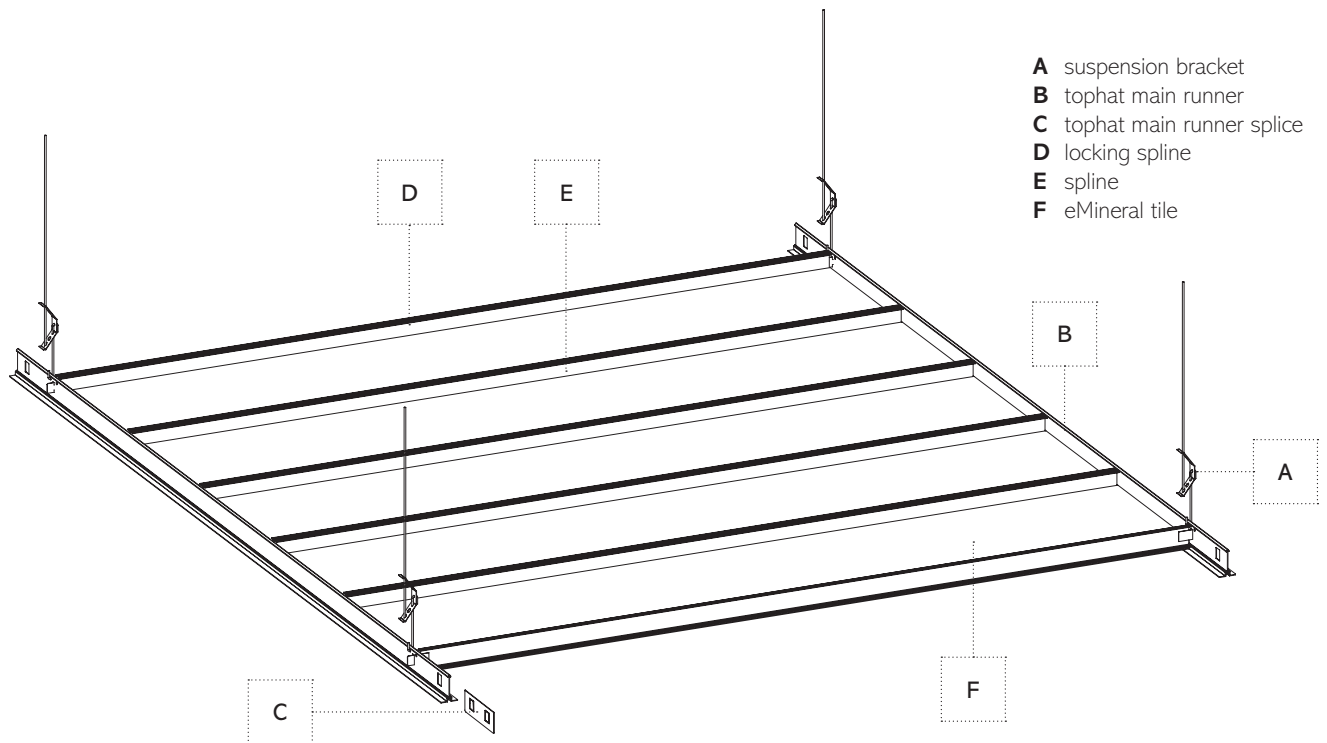

Section

