

Enterprise **230**

Lay-on metal panel in exposed one-way grid.

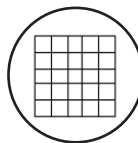

**ENTERPRISE
ARCHITECTURAL**
Metal Ceiling Solutions



EXPOSED GRID



UP TO 1.0 NRC



GROUP 1



RECYCLABLE



25 YEAR WARRANTY



Product	Enterprise 230
Grid	32mm x 55mm aluminium top hat grid, exposed 1-way
Size	Length up to 1500mm, width up to 600mm. Bespoke sizes on request
Material	Steel or Aluminium
Perforation	Compatible with Enterprise perforation patterns, bespoke patterns on request
Finish	Polyester powder-coated (PPC) Timber effect Bespoke finishes on request
Acoustic	Acoustic fleece, pad or board. Performance is dependent on pattern open area and infill. Absorption: up to 1.0 NRC Attenuation: up to 37dB
Fire	NCC Group 1 (ISO 9705:2016)
Environment	Global GreenTag GreenRate Level A Low VOC ISO 14001 and ISO 9001 Recyclable and designed for disassembly Product stewardship program
Technical	Services integration supported Seismic: project specific

Isometric

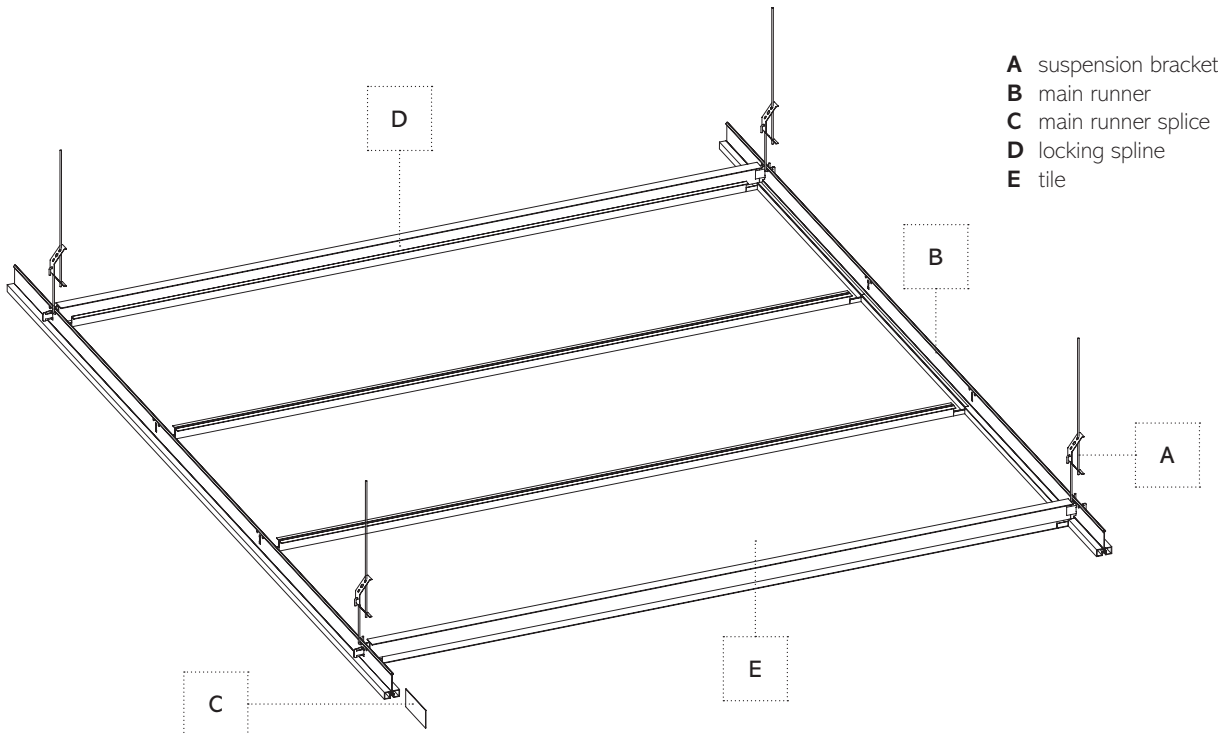

Section

